

UGL REGIONAL LINX



MINIMUM OPERATING REQUIREMENTS FOR ROAD-RAIL INFRASTRUCTURE MAINTENANCE VEHICLES

CRN-STD-ROL-713026361-492

CRN RS 006

LINKING
COMMUNITIES.

CONNECTING
CUSTOMERS.



Table of Contents

Document Control	iv
Summary of changes from previous version	iv
1 Introduction	1
1.1 About this standard	1
1.2 Rolling stock standards suite	1
1.3 Standard development	1
1.4 Australian Standards for Railway Rolling Stock	2
1.5 Definition of a road-rail infrastructure maintenance vehicle	2
1.6 Road-rail vehicle design	2
1.7 Road-rail vehicles authorised to operate on the NSW Country Regional Network	3
1.8 Acceptance of new road-rail vehicles	3
1.9 Change of road-rail vehicle design or operating conditions	4
1.10 Vehicle de-certification	4
1.11 Testing and certification of road-rail vehicles	4
2 Road-rail vehicle clearance requirements	5
2.1 Maximum road-rail vehicle outline	5
2.2 Road vehicle ground clearance	7
2.3 Road vehicle rail clearance	8
2.3.1 Vehicle load supported on all rail wheels	8
2.3.2 Road wheel loads supported on rail	9
3 Vehicle rail guidance equipment requirements	10
3.1 Wheels	10
3.1.1 Wheel design	10
3.1.2 Insulated wheels	10
3.1.3 Rail Wheel Vertical loading	10
3.1.4 Wheel diameter	12
3.1.5 Wheel width	12
3.1.6 Wheel web and rim shape	13
3.1.7 Wheel Tread Profiles	13
3.1.8 Wheel back to back measurement	14
3.1.9 Wheel – Rail Operating Dimensions and Clearances	15
3.1.10 Witness marks	15
3.2 Axles	16
3.2.1 Guide wheel axles	16
3.2.2 Drive wheel axles	16
3.3 Axle bearings	16
3.4 Rail guidance suspension	16
3.4.1 Vehicle load supported on all rail wheels	16



3.4.2	Partial vehicle load supported on front rail wheels	16
3.4.3	Vehicle load supported on all road wheels	17
3.5	Rail guidance equipment structure	17
3.6	Rail gear deployment system.....	17
3.6.1	Hydraulic components.....	17
3.6.2	Actuators	17
3.6.3	Hydraulics	18
3.6.4	Control and safety	18
3.6.5	Emergency rail gear retraction	18
3.6.6	Transferring to and from rail operation	18
4	Vehicle traction system	18
5	Brake equipment	18
5.1	Retardation brake	18
5.2	Parking brake	19
5.3	Brake performance.....	19
5.3.1	Deceleration requirement	19
5.3.2	Worksite only stopping distance requirement	20
6	Reflective Delineators	20
7	Marking and lettering	20
7.1	Road registration and/or plant No	20
7.2	Rail industry certification	20
7.3	Compliance plates	21
8	Road-rail vehicle ride performance.....	21
9	Elevating work platforms (EWPs).....	22
9.1	Design registration.....	22
9.2	EWP on-track stability.....	22
10	Towing & Recovery	23
11	Protective structures	23
12	Safety equipment	23
12.1	Speed indicating device	23
12.2	Data logger	23
12.3	Driver safety system	24
12.4	Lighting.....	24
12.4.1	Head lights	24
12.4.2	Tail, stop, marker and flashing lights.....	24
12.5	Audible Warning Device	24
12.6	Height, slew and reach restrictors.....	25
12.7	Electrical.....	25
12.8	Access	25
12.9	Maintenance	25



13	Testing	25
14	Road-rail vehicles operating as a locomotive	25
14.1	General	25
14.2	Vehicle identification	25
14.3	Authorisation of the vehicle	26
14.3.1	Brakes and pneumatic equipment	26
14.3.2	Couplers	26
14.3.3	Traction performance	26
14.3.4	Braking performance	26
14.3.5	Safety equipment	26
14.3.6	Operation of infrastructure vehicle as a locomotive	27
14.3.7	Driver safety system	27
Appendix 1	CRN Rolling Stock Glossary	28

Document Control

Function	Position	Name	Date
Approver	A&E Manager	Lucio Favotto	25.11.2021

Revision	Issue Date	Revision Description
2.1	12.11.2021	UGLRL Operational Standards Template applied
3.0	25.11.2021	First approved and issued UGLRL version of this document
4.0	23.12.2022	Added 12.7, 12.8, 12.9 and various wording improvements

Summary of changes from previous version

Section	Summary of change
All	This document is based on the previous rail infrastructure maintainer (RIM). Full revision history is available on request from UGLRL

1 Introduction

1.1 About this standard

This standard covers the minimum technical requirements for operation of road-rail infrastructure maintenance vehicles on the NSW Country Regional Rail Network (CRN).

In the context of this document the word “vehicle”, “road-rail vehicle”, “RRV”, “Hi-Rail” or “High Rail” shall be taken to mean “road-rail infrastructure maintenance vehicle”.

UGLRL has established interface requirements pertaining to all rail vehicles operating on the CRN. The requirements in this standard shall be read in conjunction with CRN RS 008, General Interface Requirements for Rolling Stock and CRN RS 010, Vehicle Acceptance Test and Inspection Requirements.

Users of this interface standard, be it owner/operators, designers, manufacturers, suppliers or maintainers of rail vehicles, or their component parts, are responsible for making their own enquiries in relation to the applicability of this standard, as well as related national standards, guidelines and codes of practice, to their own situation or need. This standard was prepared with an awareness of known road/rail vehicle interface risks and seeks to address each of those risks, however it is the end users’ duty of care, in preparing their own specifications, designs, processes and procedures, to assess the risks associated with and/or peculiar to their own situation.

When the words “shall” or “must” are used in this document, the requirements shall be read as mandatory for vehicles operating on the CRN.

When the word “should” is used in this document, the requirements shall be read as recommended, however the owner/operator will be expected to demonstrate a sound reasoning as to why the clause was not adopted.

When the word “may” is used in this document, the requirements shall be read as advisory, however the owner/operator will be expected to demonstrate a sound reasoning as to why the clause was not adopted.

The requirements of this standard will apply to all new, substantially modified road/rail infrastructure maintenance vehicles and road/rail infrastructure maintenance vehicles that have not operated previously on the CRN. Road/rail infrastructure maintenance vehicles that have operated on the CRN prior to 30 January 2022 and have a current rail certification at the time of proposed use will be considered as deemed to comply with this standard.

Road/rail infrastructure maintenance vehicles that do not have a current rail certification will not be permitted to operate or work on the CRN until such certification is obtained using the method in CRN Standard CRN RS 016 Road-Rail Vehicle Certification and Recertification.

In this standard, the terms “owner”, “operator” and “owner/operator” are used. They refer to the owner of the rolling stock, the operator using that rolling stock or, where both owner and operator are the one organisation.

1.2 Rolling stock standards suite

This standard is a part of a suite of rolling stock standards (RS-0xx) covering the interface between rolling stock and the CRN operating environment. These can be obtained from the UGLRL website.

1.3 Standard development

This CRN standard was developed from existing standards that were originally issued by the Rail Infrastructure Corporation to the ARTC for the technical management of rolling stock operating on the NSW country and defined interstate network. Those standards have been further enhanced and updated using relevant data from RailCorp interface standards, the ROA Manual and the Australian Standards for Rolling Stock. The following flow chart shows the origins and development stages of the standard.

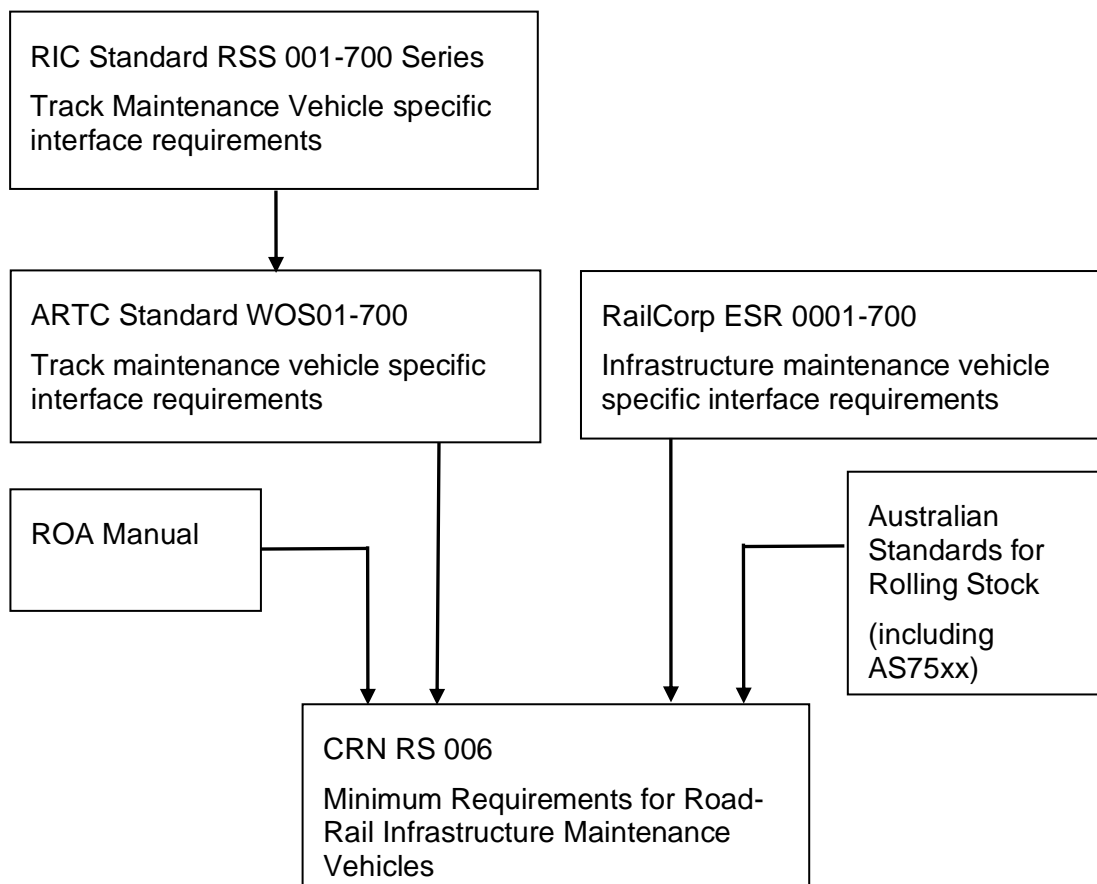

1.4 Australian Standards for Railway Rolling Stock

The current listing of Australian Standards for Railway Rolling Stock can be found on the website: www.rissb.com.au.

1.5 Definition of a road-rail infrastructure maintenance vehicle

For the purposes of interpretation of this standard a road-rail infrastructure maintenance vehicle is a road vehicle modified to also operate on rail and specifically designed to carry out inspection, maintenance and construction of railway infrastructure.

1.6 Road-rail vehicle design

Road-rail vehicle design must generally comply with the interface requirements of this minimum operating standard. Where the Australian Standards for Railway Rolling Stock have been published, then compliance may be required with those standards also.

The ROA Manual of Engineering Standards and Practices was produced primarily to cover new or substantially modified vehicles operating on the interstate standard gauge rail network, therefore reference is also made to, and excerpts are included from the ROA Manual of Engineering Standards and Practices, where applicable.

The design of any road-rail vehicle shall also take into account the requirements of the Occupational Health and Safety Act, however this standard does not specifically cover Occupational Health and Safety requirements, which fall within the responsibility of the vehicle owner/operator.

For road/rail vehicles fitted with cranes, hoists or winches, such equipment must comply with the requirements for selection, operation and maintenance as specified in AS 1418 - Cranes, Hoists and Winches and AS 2550 – Cranes, Hoists and Winches – Safe use. The lifting and/or elevating equipment manufacturer and date of manufacture must be listed on an identification plate suitably affixed to the equipment.

Similarly, a manufacturer's identification plate recording the following information shall affixed to the front and rear rail guidance equipment:

- Rail guidance equipment manufacturer
- Road-rail vehicle manufacturer's name
- Date of rail guidance equipment installation
- Equipment serial number

The design of any road-rail vehicle shall take into account and demonstrate compliance with the requirements of all environmental legislation, in particular those requirements relating to noise, vibration, exhaust emissions and waste discharge, where applicable.

Newly introduced or substantially modified road-rail vehicles are subject to review and assessment by the CRN Manager for compliance with the relevant standards and legislation. Road-rail vehicle owner/operators will be required to submit the necessary documentary evidence to verify that their vehicle is compliant and rail certified.

Road-rail vehicles that do not fully comply with the standards and legislative requirements may be permitted to operate under nominated restrictions as determined by the CRN Manager.

1.7 Road-rail vehicles authorised to operate on the NSW Country Regional Network

Only road-rail vehicles, rail certified and approved to operate on the CRN will be able to operate on the CRN. There is no mutual recognition in place for certification on other networks.

Road-rail vehicle owner/operators shall be responsible for obtaining rail certification through an approved certifying body (listed in RS-016) and gaining vehicle acceptance from the CRN Manager.

To be fully accepted on to the CRN, Road Rail Vehicles must have their relevant operating details published in the CRN Train Operating Conditions (TOC) Manual or on a TOC Waiver.

Road-rail vehicles not published in the CRN Train Operating Conditions manual shall not be operated or moved on the CRN unless special approval in the form of a CRN TOC Waiver is issued. This approval is required for any movement including that of vehicles undergoing tests.

Road-rail vehicles with a defect as specified herein, sufficient for that vehicle to be removed from service, detected or known to be operating, on an adjacent rail network, shall not enter the CRN without the authority of the CRN Manager.

All road-rail vehicles must be maintained in a condition that meets or exceeds the minimum operating requirements contained in this standard. Where it is deemed that the condition of a road-rail vehicle has deteriorated below these minimum requirements, then the authority to operate that vehicle on the CRN may be withdrawn until it can be demonstrated that the vehicle roadworthiness has been reinstated.

1.8 Acceptance of new road-rail vehicles

To apply for new road-rail vehicle acceptance the owner/operator shall complete the appropriate Vehicle Certification Request Form, CRN RF 006 in conjunction with an accredited Certification body and submit it to the CRN Manager. Refer to CRN Standard CRN RS 016 - Road-Rail Vehicle

and Trailer-Trolley Certification and Recertification Appendix 4 for a listing of Accredited Certifying Bodies.

Where testing is to be conducted on the road-rail vehicle/s refer to section 1.11 below.

Once a vehicle/s has been approved, details of the vehicle/s will then be published in the CRN Train Operating Conditions manual, or a TOC waiver, along with any special operating conditions.

Vehicle acceptance is based on each vehicle's rail operating compatibility with the CRN only and does not warrant the structural integrity of the vehicle, based on design and/or construction. Vehicle acceptance for operation on the CRN requires that such vehicles continue to be maintained fit for purpose, in accordance with the accredited Owner/Operators' vehicle maintenance standards.

1.9 Change of road-rail vehicle design or operating conditions

Where a road-rail vehicle has been modified or is proposed to be modified, such that the modification is going to impact on the vehicle's performance, then the owner/operator must advise the CRN Manager and apply for a vehicle re-approval.

This applies to any modifications that may affect the vehicle's on-track performance such as flexibility of the vehicle's structure, suspension stiffness, braking performance, increase in adhesion performance, loading capacity, load imbalance of the vehicle, etc.

See Clause 1.10 for road-rail vehicle de-certification criteria.

1.10 Vehicle de-certification

Road/rail vehicles will be de-certified under any of the following circumstances:

- Annual Inspection overdue
- Worksite (including track and off-track) incidents involving damage or potential damage to rail guidance equipment
- Unauthorised road/rail vehicle modifications

Such vehicles must undergo the re-certification process before the vehicle certification and operating approval will be restored.

Refer to CRN Standard CRN RS 016 Road-Rail Vehicle and Trailer/Trolley Certification and Recertification.

1.11 Testing and certification of road-rail vehicles

Testing of any road-rail vehicle/s on the CRN shall not be carried out without the prior approval of the CRN Manager and the issuance of an appropriate CRN TOC Waiver.

New or substantially modified road-rail vehicles shall successfully undergo inspection and testing in accordance with the guidelines and tests specified in CRN Standards CRN RS 008 and CRN RS 010, respectively, being conducted prior to acceptance, to confirm safe operation and compliance with the appropriate regulatory requirements.

Road-rail vehicles will be required to be rail certified on a 12 monthly basis for operation on the CRN. This will require owners/operators to have their vehicles tested and inspected annually, to verify that the vehicle conforms to CRN standards. Annual certifications may be conducted up to 30 days early in order to maintain the same expiry date. Annual certifications performed late may require additional compliance checks and are at the discretion of the CRN manager.

Test/inspection results are recognised only if undertaken by an Approved Certifying Company. Refer to CRN Standard CRN RS 016, Appendix 4 for a list of approved certifying companies. All re-certifications must be accompanied by a completed Road/Rail Re-certification Checklist (Refer to CRN Standard CRN RS 016, Appendix 2).

For road/rail vehicles fitted with elevating/load lifting equipment, such equipment must be registered in accordance with local and federal laws.

The CRN Manager reserves the right to:

- have a representative present for each of the inspection/tests.
- request the owner/operator to conduct further testing where it is suspected that the vehicle performance has deteriorated.
- have access to all relevant raw test data (this may apply to a number of tests).

Once the CRN Manager is satisfied with the performance of the road-rail vehicle/s, further testing may be carried out at the discretion of the owner/operator but only with prior notification and agreement of the CRN Manager.

2 Road-rail vehicle clearance requirements

2.1 Maximum road-rail vehicle outline

For safe operation, a road-rail vehicle, in rail and road travel mode, shall not infringe the limits of the vehicle outlines as depicted in Figure 1 below. In rail work mode, whilst stationary or operating within a controlled worksite, the vehicle may exceed these specified limits provided that movements are continuously monitored, or the items causing infringement are retractable and interlocked with the vehicle travel mode control system.

The solid line shown in Figure 1 depicts the maximum cross-sectional envelope for a road vehicle capable of operating on rail. The broken lines depict the additional cross-sectional area which can be accommodated by a road-rail vehicle when operating on rail, in travel mode.

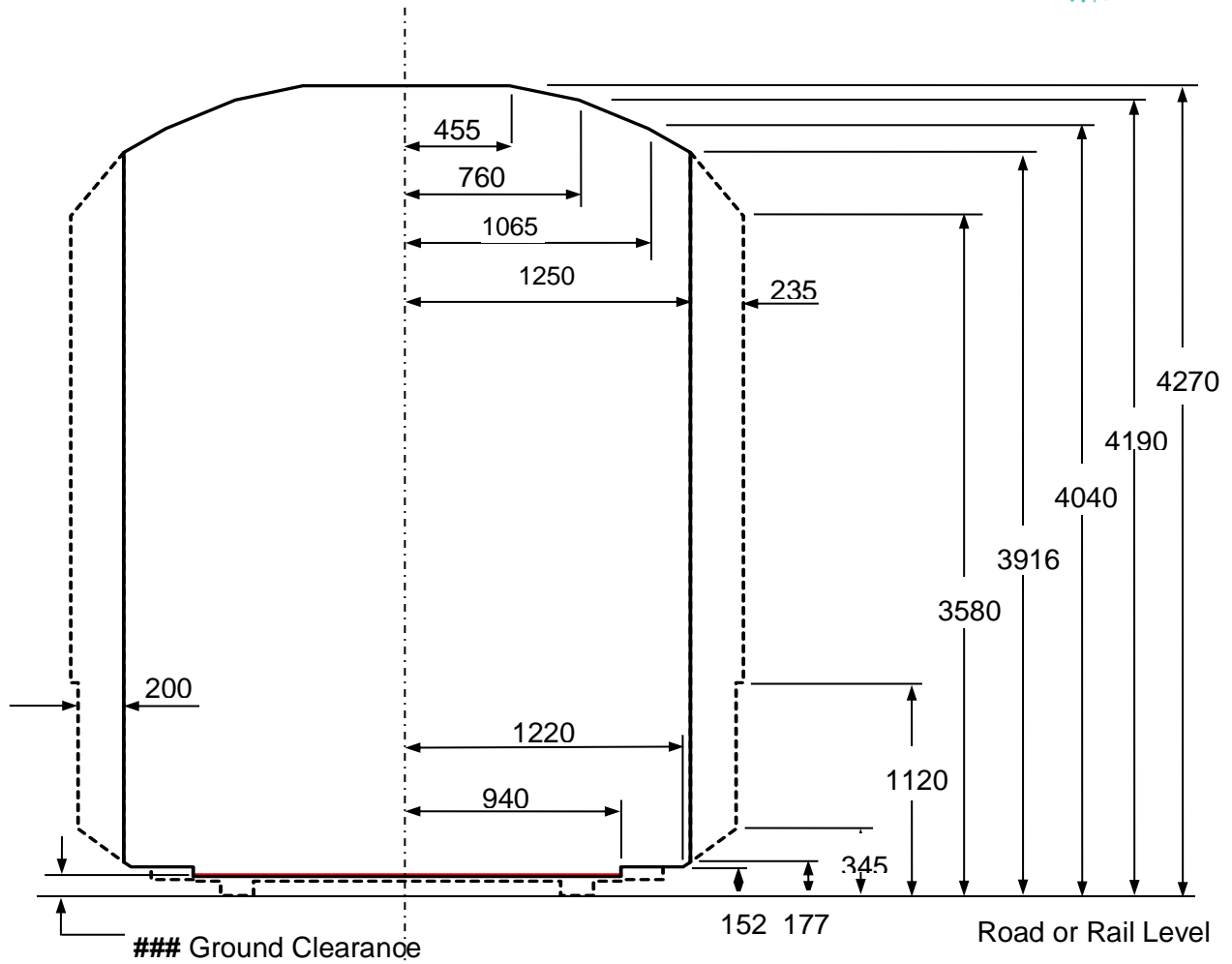

Figure 1 – Maximum Road/Rail Vehicle Outline

Minimum Running Ground Clearance, for road operation, refer to Clause 2.2

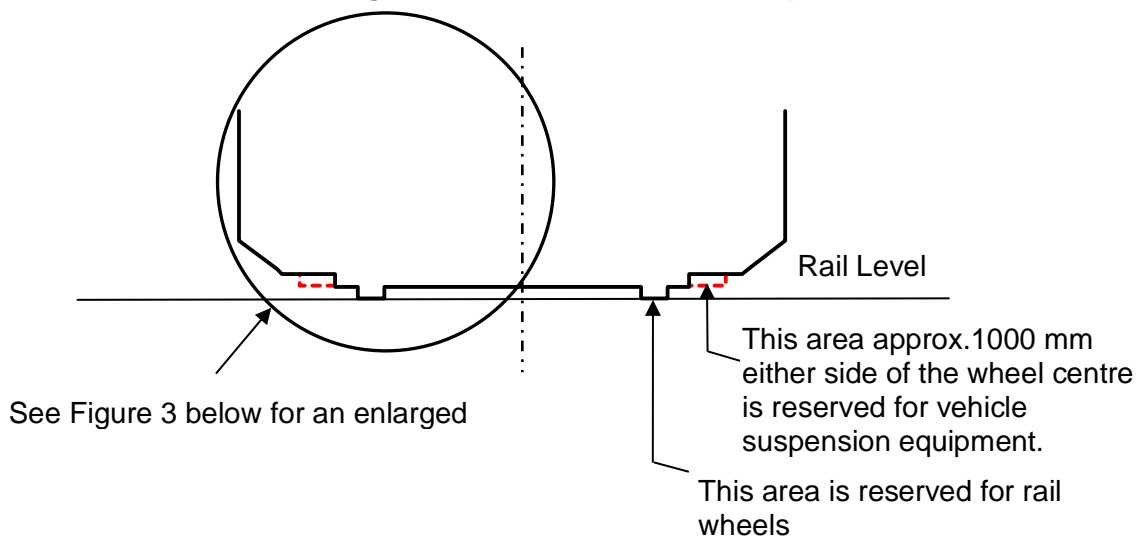

Figure 2 – Rail Vehicle Equipment Clearances

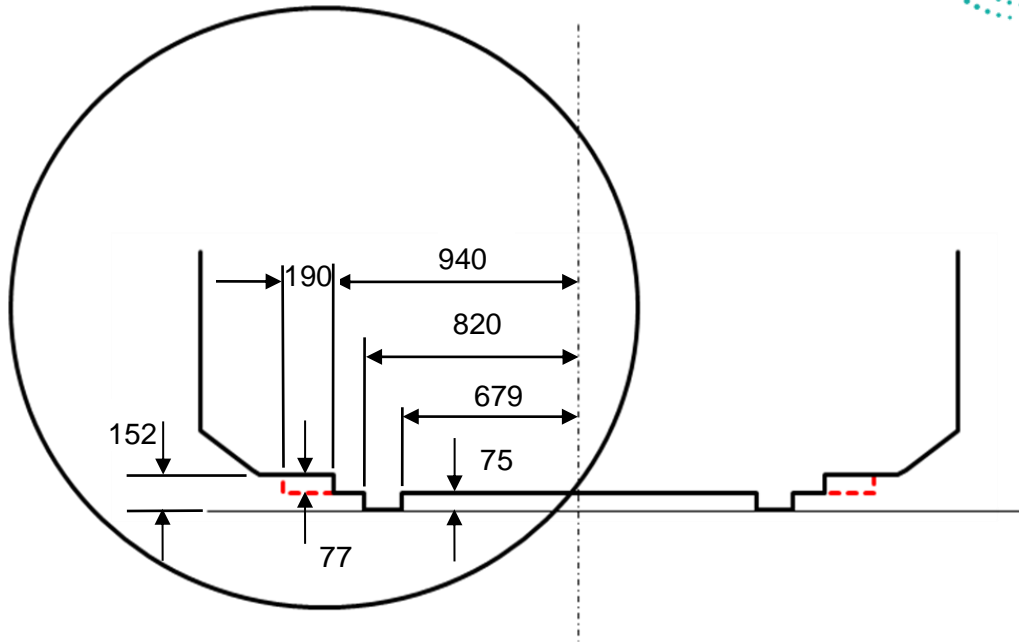

Figure 3 – Rail Vehicle Ground Clearances

2.2 Road vehicle ground clearance

Normal ground clearance requirements for road vehicles is 100 mm minimum for any point within one (1) metre, fore and aft, of any axle for the full width of the vehicle, however for road vehicles required to access rail track, the approach clearance angle from either end of the vehicle should be at least 15 degrees or 1 in 3.75 . Refer to Figure 4.

For any other point under the vehicle, the ground clearance shall be such that if the wheels of one (1) axle are on one (1) plane of 1 in 15 gradient and the wheels on the next consecutive axle are on another plane with an opposing 1 in 15 gradient, the point in question, will pass unrestricted, over the transverse apex of the two (2) intersecting planes, as shown in Figure 5. The height “H” of the peak of the intersecting planes shall not be less than 100 mm. See Figure 5 below.

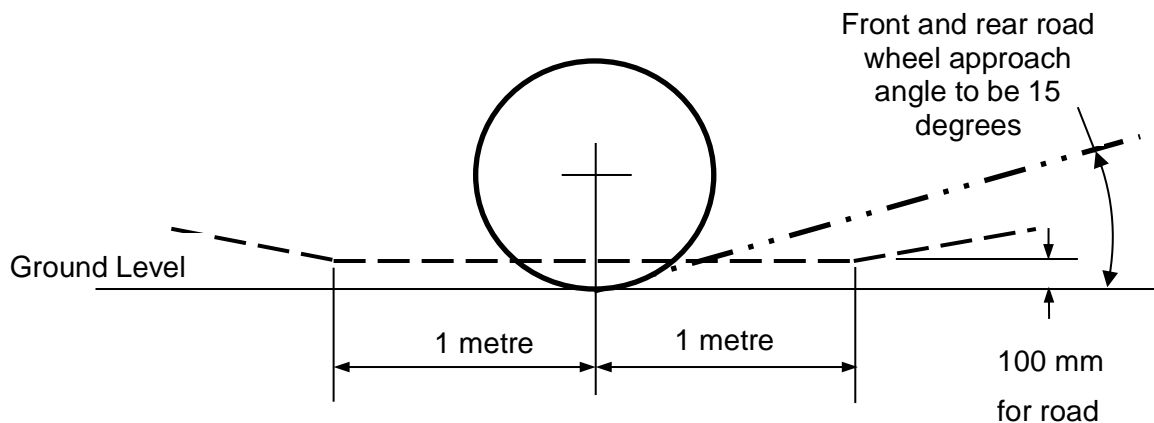
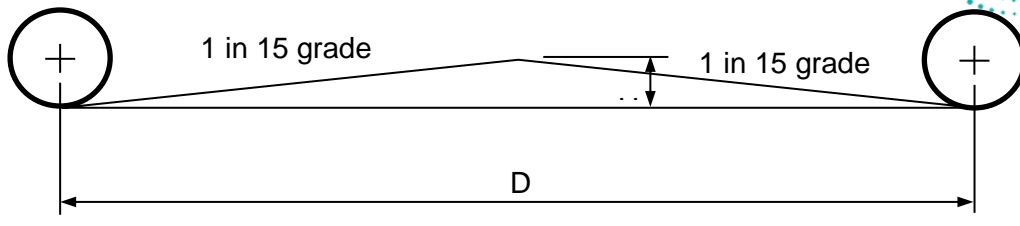

Figure 4 – Road Vehicle Axle Ground Clearance



D = Distance between consecutive axles
 H = Minimum ground clearance (mm)
 = 0.033 D (but not less than 100 mm)

Figure 5 - Road Vehicle Body Ground Clearance

2.3 Road vehicle rail clearance

The clearance between rail road wheels is dependent on the type of vehicle drive system on rail, and the operating conditions.

2.3.1 Vehicle load supported on all rail wheels

Road-rail vehicles which are fully supported on rail wheels must have adequate clearance above rail otherwise they will have restricted operation because of track based equipment such as high check rails, housed points and train stops. Vehicles constructed within the road wheel space dimensions shown in Figure 6, are unrestricted in their operation.

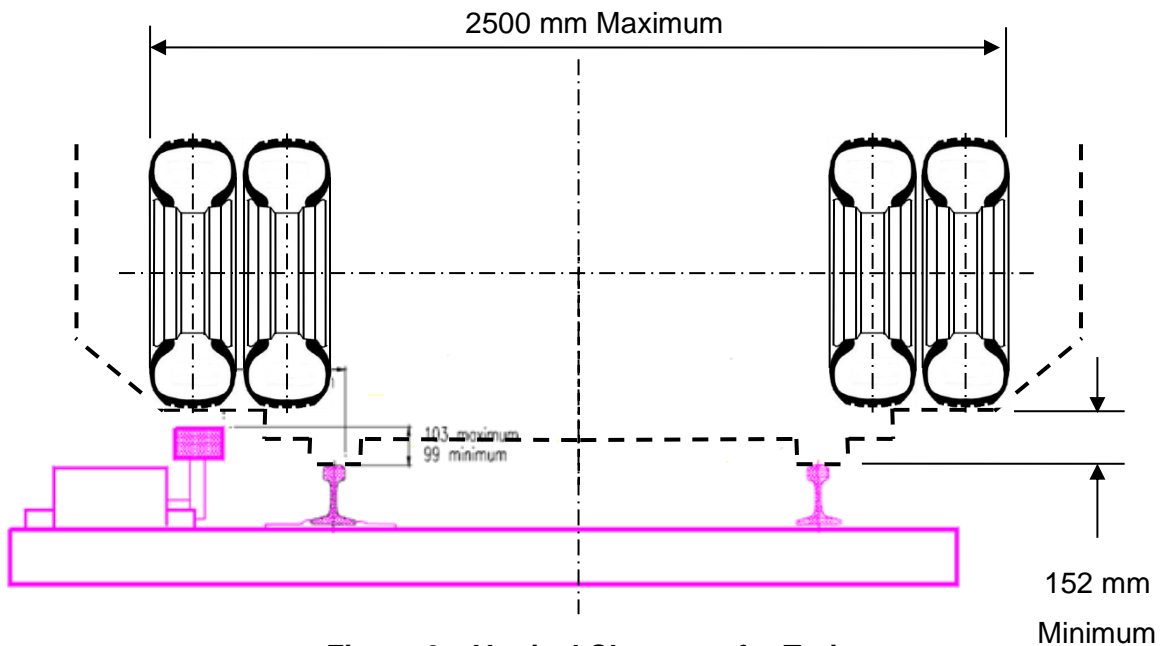

Figure 6 – Vertical Clearance for Train

2.3.2 Road wheel loads supported on rail

Road-rail vehicles with single road wheels, wheel loads supported by the rails and constructed within the road wheel space dimensions shown in Figure 7, are unrestricted in their operation, and are not affected by track based equipment such as high check rails and housed points.

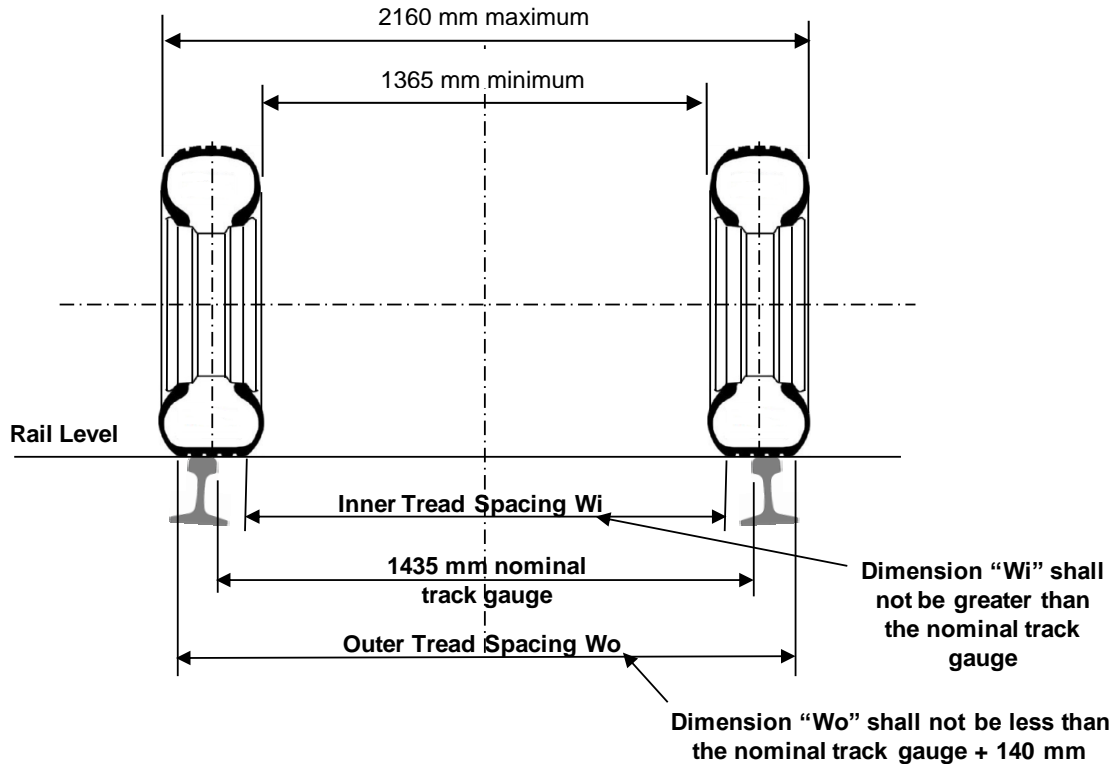

Figure 7 – Single Road Wheel Application

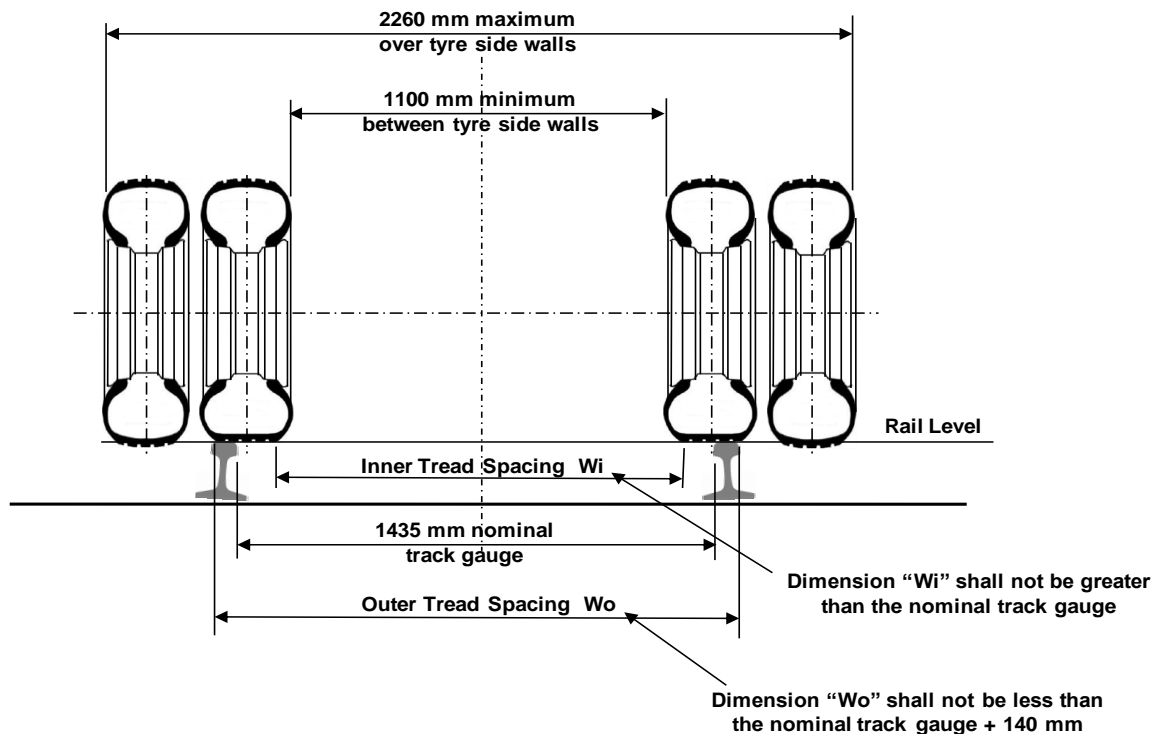

Figure 8 – Dual Road Wheel Application

Road-rail vehicles with dual road wheels, the inner wheel loads supported by the rails and constructed within the wheel space dimensions shown in Figure 8 are covered by Note T12 in the CRN Train Operating Conditions (TOC) Manual and are therefore restricted in their operation to 20 km/h in the forward and 5 km/h in the reverse direction when traversing track fitted with check rails or guards rails, such as at points, crossings, bridges and level crossings.

3 Vehicle rail guidance equipment requirements

The following sections cover vehicle rail running gear component requirements which are specific to the operating safety of road-rail vehicles. Refer to CRN Standards CRN RS 008 and CRN RS 010 for general interface requirements and testing requirements, respectively.

3.1 Wheels

3.1.1 Wheel design

Road-rail vehicle wheels shall be designed, generally in accordance with accepted railway standards.

Depending on wheel loads and the duty cycle, wheels and wheel materials designed and manufactured to alternate rail industry standards will be considered.

3.1.2 Insulated wheels

Track signal activation is effected by bridging out the two (2) running rails thus short circuiting (shunting) the signal currents carried through the rails. For track signal activation the resistance between the two (2) wheels on the same axle must be less than 1 milliohm (0.001 ohm) at 1 Volt.

Road-rail vehicles normally have lower wheel loads than that conventional rolling stock with usually only two (2) or four (4) wheels on track which makes signal shunting unreliable thereby introducing the risk of road-rail vehicles not activating the signals or showing up on the network control system.

It is therefore a requirement that road-rail vehicles have electrical isolation between wheels on adjacent rails to ensure that it is not possible to shunt signal circuits. To prevent track signal activation the resistance between the two (2) wheels, on the same axle, must be greater than 1kohms (1000 Ohm) at 500V. For this reason all road-rail vehicle must operate either within a track possession or under block working when on the main line.

3.1.3 Rail Wheel Vertical loading

Rail wheel vertical loading can be divided into three (3) vehicle configurations.

- The complete vehicle load is carried on the rail wheels
- The vehicle load is shared between the front rail wheels and the rear road wheels, with the rear rail wheels being used for guidance only.
- All road wheels carry the bulk of the vehicle load on rail with all rail wheels being used for guidance only.

3.1.3.1 Vehicle load supported on all rail wheels

The vertical load on any fully load supporting rail wheel will be governed by the maximum permitted road loading for the vehicle/axle/tyre configuration as shown in Table 1.

The lateral wheel loading shall be based on vehicle lateral inertial forces.

Axle/Tyre Configuration	Road vehicle mass limits/axle for single axles and axle groups
Single axle or single axle group fitted with single tyres with a section width of:	
(a) less than 375 mm	6.0 tonnes
(b) 375 mm or more but less than 450 mm	6.7 tonnes
(c) 450 mm or more	7.0 tonnes
Single axle or single axle group fitted with dual tyres	9.0 tonnes
Tandem axle group fitted with single tyres with section width of:	
(a) less than 375 mm	11 tonnes
(b) 375 mm or more but less than 450 mm	13.3 tonnes
(c) 450 mm or more	14 tonnes

Table 1 – Road Vehicle Mass Limits per Axle

For vehicles where the mass of a road-rail vehicle is fully supported on rail wheels, the maximum expected static rail wheel loads are as shown in Table 2.

Axle/Tyre Configuration	Permitted Vertical Load per Rail Wheel
Single axle or single axle group fitted with single tyres with a section width of:	
(a) less than 375 mm	29.43 kN (3.0 tonnes)
(b) 375 mm or more but less than 450 mm	32.86 kN (3.35 tonnes)
(c) 450 mm or more	34.34 kN (3.5 tonnes)
Single axle or single axle group fitted with dual tyres	44.15 kN (4.5 tonnes)
Tandem axle group fitted with single tyres with section width of:	
(a) less than 375 mm	53.96 kN (5.5 tonnes)
(b) 375 mm or more but less than 450 mm	65.24 kN (6.65 tonnes)
(c) 450 mm or more	68.67 kN (7 tonnes)

Table 2 – Permitted Load on Rail per Wheel

3.1.3.2 *Partial vehicle load supported on front rail wheels*

The vertical load on any fully load supporting front rail wheel will be governed by the maximum permitted road loading for the front road wheels and the position of the rail wheels in relation to the front road axle. Rail wheels located behind the front road axle shall be designed for a higher loading than that permitted on the front road wheels.

The design load on the rear rail wheels shall ensure adequate vertical wheel load, consistent with meeting track twist requirements, together with lateral rail wheel guidance forces.

3.1.3.3 *Rail wheels used as guide wheels only*

Where the vehicle mass is substantially supported on rail by its road wheels the rail wheel design loads shall be based on providing adequate vertical load, consistent with meeting track twist requirements, together with lateral rail wheel guidance forces.

3.1.4 Wheel diameter

The wheel diameter is measured at the wheel tread centre line, which is 70 mm from the back face of the wheel, as shown on the relevant profile drawing.

In determining and/or approving vehicle operating conditions, the CRN Manager will consider maximum axle load and the maximum P/D ratio, (i.e. the ratio of maximum static wheel load to minimum [worn] wheel diameter).

The maximum allowable P/D ratios for operation of **worn wheels** on the CRN are specified in CRN Standard CRN RS 008, Section 3.4 Table 2

Where it is proposed to operate vehicles having P/D ratios exceeding these limits, approval must be obtained from the CRN Manager.

Refer to CRN Standard CRN RS 008, Section 3.4 Table 3 for currently approved bogie/wheel load/wheel diameter combinations for new wheels.

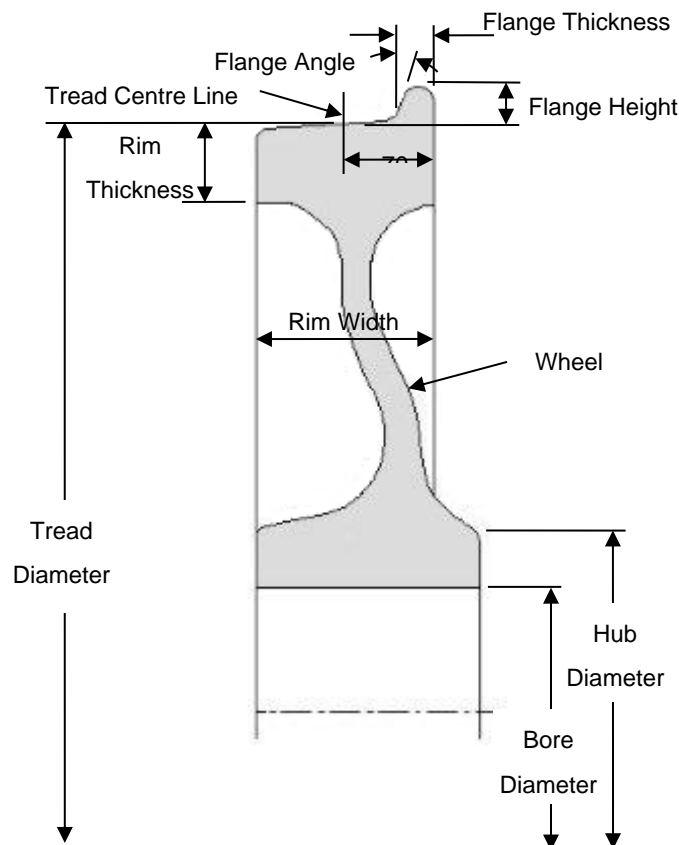

Figure 9 – Wheel parts and principal dimensions

3.1.5 Wheel width

Wheel overall width, measured from the back of the flange to the wheel rim face, shall nominally range from 120 mm to 140 mm, with 140 mm being preferred, and mandatory for wheels where the P/D ratio exceeds normally accepted levels.

3.1.6 Wheel web and rim shape

Wheel web shape shall be designed to suit the wheel application. The wheel web shall be positioned to support the vertical and lateral wheel loads and load eccentricities carried at the wheel rim and flange, and effectively transfer that loading to the wheel bearings.

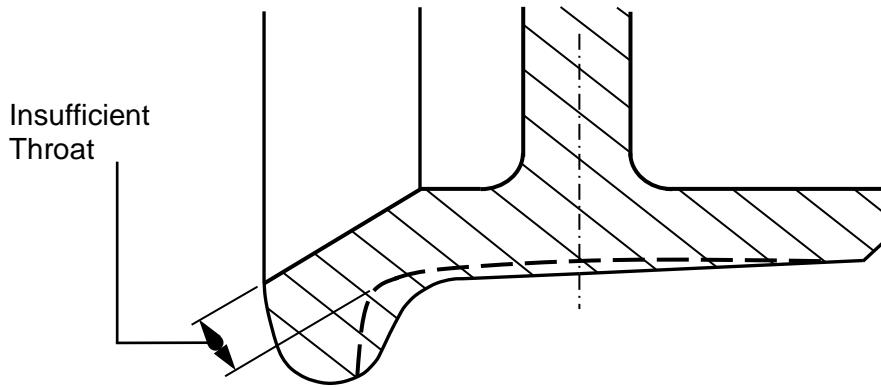

Figure 10 – Insufficient Throat Thickness

Care shall be taken in designing the wheel to avoid excessive relief at the back of the wheel rim which can result in insufficient flange throat thickness when tread and flange wear are taken into account. Refer to Figure 10 above.

3.1.7 Wheel Tread Profiles

Figures 11 and 12 show the recommended wheel tread profiles for rail wheels fitted to road-rail vehicles. Worn wheel tread profiles, such as the WPR2000, are of no real advantage to road-rail vehicle operation and may result in excessive lateral vibration of the guide wheels during operation on tangent (straight) track and thus, are not recommended.

NOTE: The AAR (American) thick flange wheel tread profile is absolutely not acceptable for Australian rail networks.

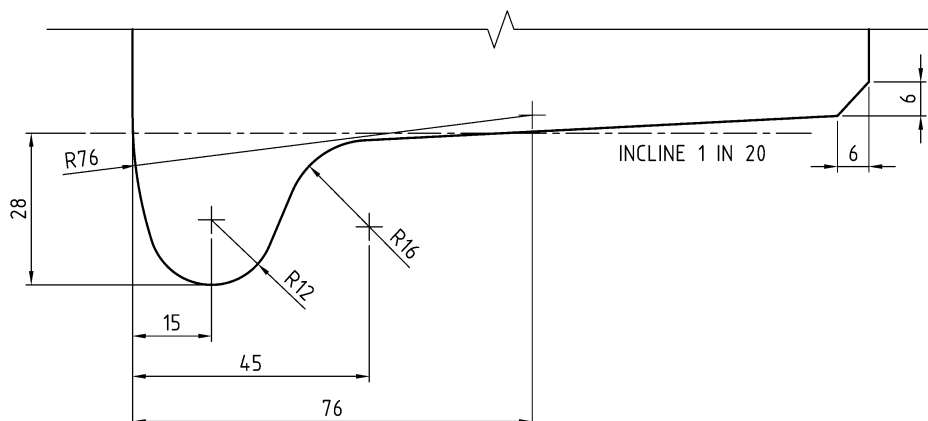

Figure 11 - ANZR1 Full Flange Wheel Profile

Figure 12 shows a 7/8 flange profile which is designed to permit the recovery of an acceptable tread/flange profile without the need to remove excessive tread material. This profile may be used on new wheels when those wheels are not normally subject to excessive flange wear.

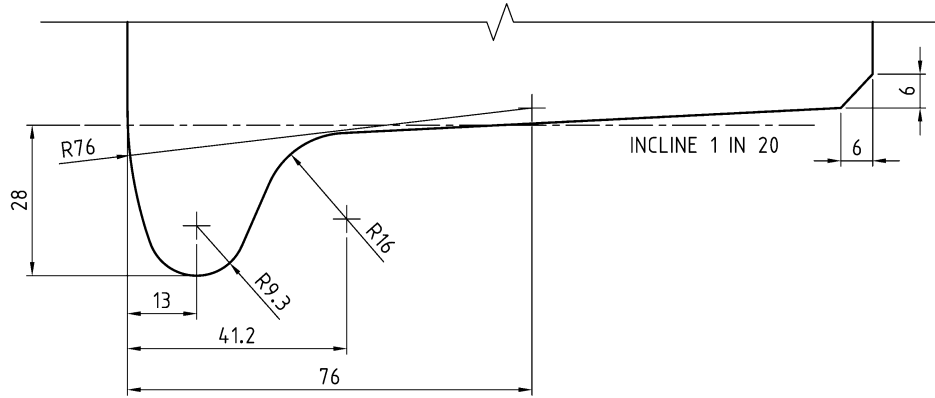

Figure 12 - ANZR1 7/8 Flange Wheel Profile

3.1.8 Wheel back to back measurement

The wheel back to back dimension is critical for safe operation and shall be measured at the 6 o'clock position at a point 40 mm inside the outer circumference of the wheel flange. The measurements between the two (2) wheels shall be within the following range. See Figure 13 below.

Minimum	1357 mm
Maximum	1360 mm

NOTE: The back to back dimension shall be taken with the wheels on the rails under their normal operating load.

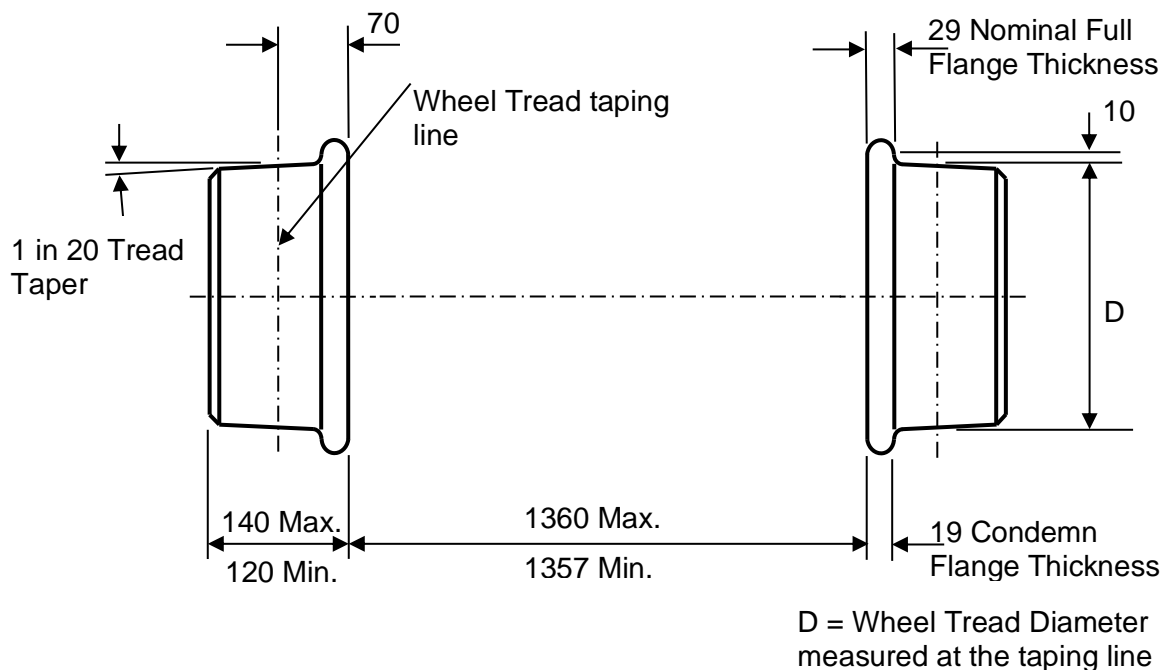

Figure 13 - Wheel Pair Controlling Dimensions

3.1.9 Wheel – Rail Operating Dimensions and Clearances

Figure 14 depicts the wheel profile – rail relationship for safe operation

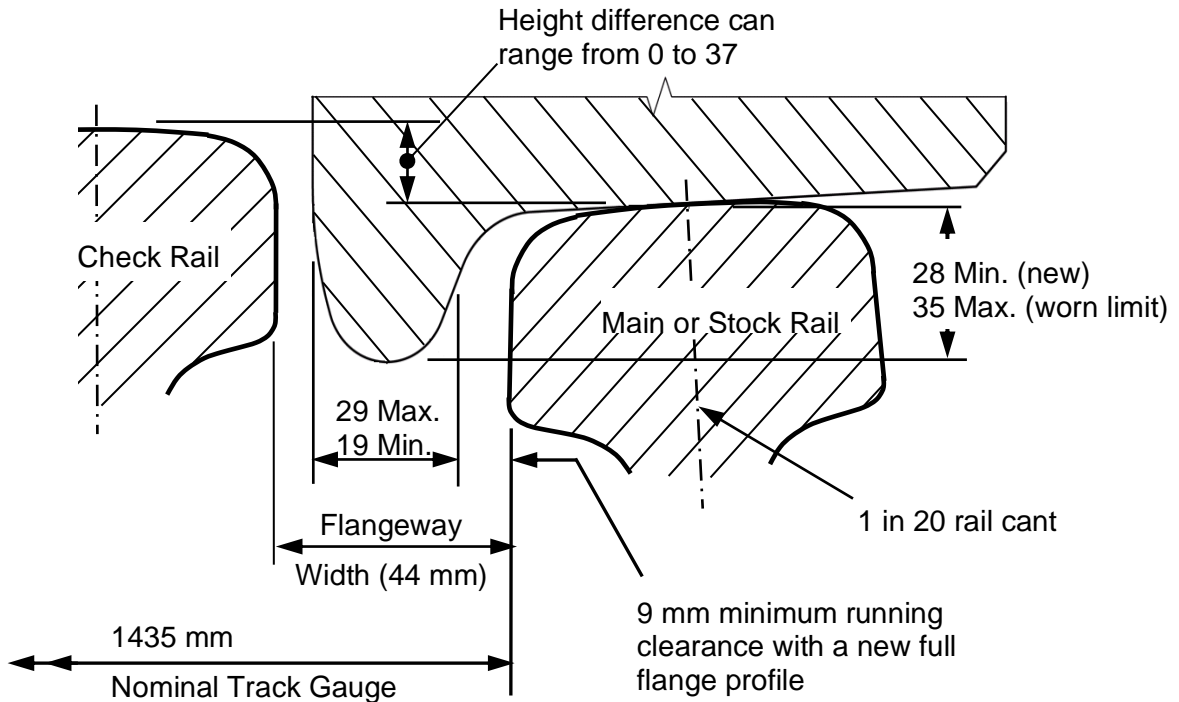

Figure 14 – Wheel - Rail Operating Relationship

3.1.10 Witness marks

Witness marks used for an indication of machining efficiency, are permitted between the flange tip and a point 10 mm above the wheel tread baseline and shall not exceed 6 mm in width.

Witness marks permitted shall only be as a result of the wheel machining process, where the witness mark represents a section of the wheel surface which has not been machined, and contains the original surface material surface. Refer to Figures 15 for an acceptable witness mark.

Witness marks shall not include wheel damage from derailments etc. or an incorrect machining process.

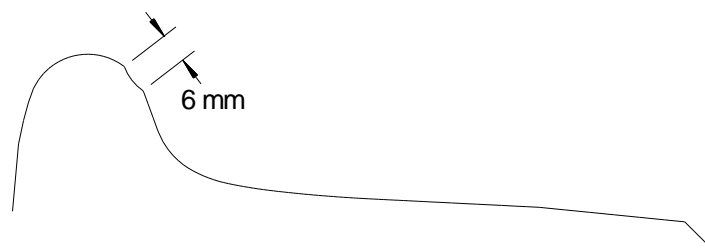

Figure 16 – Witness mark dimensional limit

3.2 Axles

The majority of road-rail vehicles use independently rotating wheels and thus the appropriate axle design is a stub axle arrangement, similar to that for a road vehicle. A fixed wheel and axle arrangement similar to that of normal rail rolling stock is not recommended unless the axle size and wheel seat connection have been appropriately designed for the imposed bending, lateral and torsional loads.

3.2.1 Guide wheel axles

Guide wheel axles are normally cantilevered from the rail guidance framework and/or suspension arms. The stub axle is a fatigue element subjected to rail wheel vertical and lateral guidance forces, as well as inertial forces, when the wheels are suspended during normal road and off-road operation. It is essential when designing stub axles that abrupt changes in section be avoided and it is preferred that the axle be over-designed to minimise bending stresses. Axle design calculations and/or FEM analysis results shall be submitted with the engineering report covering the rail guidance equipment design

3.2.2 Drive wheel axles

Axles that are required to transmit tractive effort and braking forces shall be designed to transmit those torsional loadings in combination with the vertical and lateral guidance forces.

In the majority of road-rail applications the tractive effort, and in some cases, the retardation (braking) forces are supplied by hydraulic motors.

3.3 Axle bearings

Axle bearings should be of robust “road vehicle” design, suitably sized to meet the duty cycle and life expectancy. The bearing assembly should be of the tapered roller or angular contact type, sized to withstand all lateral and eccentric forces and be capable of being adjusted to accommodate wear.

The bearing assembly must be provided with adequate seals with provision for externally applied lubrication.

3.4 Rail guidance suspension

The road-rail vehicle suspension system design will depend on the type of rail wheel load support requirements.

3.4.1 Vehicle load supported on all rail wheels

The suspension system shall be designed to fully support its share of the vehicle mass with sufficient spring travel to provide an acceptable ride quality for personnel comfort and to accommodate the track twist requirements without exceeding 60% loss of vertical wheel loading. Refer to CRN Standard CRN RS 010 for twist test requirements.

NOTE: The use of a Flexitor suspension system is presently not suitable for wheel loads in excess of 24.5 kN (2.5 tonnes).

An alternate suspension system can involve the use of a centre pivoting axle which can be used to negate the twist test requirements provided there is sufficient pivot deflection to accommodate the track twist. The pivoting axle may not require a suspension system but must have sufficient guidance to prevent angular axle displacement about its vertical axis.

Vehicles such as excavators may not be suitable for a conventional sprung suspension system. In this case a pivoting axle is essential to meet the track twist requirements.

3.4.2 Partial vehicle load supported on front rail wheels

Where rail wheels are used to carry the front vehicle portion of mass and the rear road wheels support the remainder of the vehicle mass on rail, the front rail suspension shall be capable of

supporting the vertical load within its design capacity. That is, the suspension elements must not be overloaded.

The pivoting axle is also suitable for this application.

3.4.3 Vehicle load supported on all road wheels

Where the vehicle is supported on rail by all road wheels, the rail wheel suspension system shall be sufficient to ensure that the rail wheels are adequately loaded to maintain rail wheel vertical contact with the rail whilst permitting the vehicle to meet the track twist requirements.

3.5 Rail guidance equipment structure

The structural components supporting the rail running gear and attaching it to the vehicle chassis shall be designed to carry and transmit all the required loads, including vertical, lateral, longitudinal static and dynamic loads as well as traction and braking reaction loads.

The structure shall be designed and constructed using accepted rail engineering methods.

Consideration shall be given to the effects on the original vehicle structure due to any increase in loading created by the rail wheel loading configuration.

The rail guidance frame shall be positioned such that when the rail wheels are retracted there shall be adequate clearance between rail wheel and road. Refer to Clause 2.2 for ground clearances in terms of ramp and approach angles.

Rail guidance equipment shall be laterally centred with respect to the vehicle body/road wheels such that the longitudinal centreline of the rail wheel configuration is within +/- 5 mm of the road vehicle longitudinal centreline.

3.6 Rail gear deployment system

Rail gear may be deployed by either hydraulic or electric actuators. In either case the rail wheel deployment shall be such that there is a positive locking once the wheels have been fully deployed. This lock may be accomplished by a mechanical latch however, an over centring mechanism is the preferred failsafe method.

3.6.1 Hydraulic components

All hydraulic installations associated with the deployment, retraction and the drive systems of rail wheels shall comply with AS2671 - Hydraulic fluid power - General requirements for systems and ISO4413 – Hydraulic Fluid Power – General Rules Relating to Systems, or equivalent.

Hydraulic hoses used with the equipment shall conform to AS3791- Hydraulic Hoses (including amendments) or equivalent. Hydraulic hoses shall be routed, clipped and shielded with burst/wear protection, as required, to protect them from kinking, abrasion due to cyclic loading and sharp edges and corners as well as pinch points.

All hydraulic and pneumatic schematics supplied in documentation shall be drawn in accordance with AS1101.1-Graphic symbols for general engineering - Hydraulic and pneumatic systems or equivalent.

The design shall be such that provision is made for ease of dismantling, maintenance and adjustment, and convenient access to components requiring regular servicing and/or inspection.

Hydraulic hose quick-connect fittings shall have secure dust proof end covers when not connected.

3.6.2 Actuators

Hydraulic and pneumatic cylinders shall comply with AS2019- Fluid power - Hydraulic and pneumatic cylinders - Bore and rod dimensions or equivalent.

Actuators, valving and limit switches shall be protected from damage

3.6.3 Hydraulics

The hydraulic system shall be fitted with a shutdown device that prevents the hydraulic pump/s operating after the fluid level in the main hydraulic tank drops significantly below the normal operating level (based on manufacturer's recommendation). The operation of the shutdown device shall be insensitive to the track gradient and superelevation.

3.6.4 Control and safety

Hydraulics and controls shall be designed to be failsafe. That is, the hydraulic pressure shall not automatically release from the power cylinders, in the event of a power or hydraulic hose failure, unless there is a positive action on the part of the operator to cause it to release.

The rail deployment system shall be fitted with safety latches to prevent unintentional deployment during non-rail operation.

3.6.5 Emergency rail gear retraction

There shall be a manual means of retracting the rail gear in the event of a hydraulic, electrical or a control failure. The emergency system shall be such that the rail gear can be retracted within a short time so that the vehicle can be cleared from the track.

3.6.6 Transferring to and from rail operation

At all stages during the transfer from road to rail and vice-versa, road-rail vehicles must be restrained to prevent the potential for a runaway. This requirement is particularly important where the road wheels are used to drive the rail wheels through a friction drive, such as with Pettibones. The rail gear deployment system shall be interlocked such that at least two (2) braked rail wheels remain in contact with the rail at all times when raising or lowering the rail guidance equipment.

This requirement also applies when using emergency hand pumps in the event of a hydraulics failure.

4 Vehicle traction system

Road-rail vehicle traction systems shall be designed to ensure that there is no loss of traction due to loss of wheel load and/or adhesion.

Friction drives using the road wheels acting directly on the rail wheels or indirectly on wheel extension drums shall be such that there is adjustment to cater for road wheel wear.

Where road wheels are used for traction acting on rail or on rail wheels or friction drums, it is important that correct tyre pressures be maintained and tyre tread wear be monitored. Excessive tread wear can reduce wheel to rail and wheel to wheel/drum adhesion both for traction and braking.

In the case of individually hydraulic driven rail wheels, to prevent an individual drive wheel from free-wheeling when it is unloaded or loses traction, it is recommended that the hydraulic drive motors be coupled in series.

5 Brake equipment

Road-rail braking equipment shall be designed to meet the vehicle drive system design and the required braking performance.

5.1 Retardation brake

Vehicles fully supported on rail wheels can employ hydraulic drive retarders, wheel mounted drum or disc brakes. In cases where the road wheels are used to drive the rail wheels the road vehicle braking system can be employed.

Refer to Clause 5.3 for brake performance requirements.

5.2 Parking brake

All road-rail vehicle shall be fitted with a failsafe parking or handbrake capable of holding the vehicle GVM whilst in rail mode, indefinitely on a 1 in 30 track gradient.

In the event that a suitable 1 in 30 gradient is not available to conduct such a brake holding test there are two (2) alternative tests available, depending on the circumstances.

- The wedge test, which involves placing all the vehicle wheels on wedges each with a 1 in 30 slope with the parking brake applied. The vehicle shall be capable of remaining stationary on the wedges indefinitely.
- The pull test, which involves applying a steady pulling force on the vehicle which is on rail with its parking brake engaged. Pulling force involves using a towing chain (not a wire rope) in conjunction with a load cell to measure the actual towing force. Based on the downhill gravitational force component of a 1 in 30 grade the braking force required to resist the grade force is $W/30$ or $0.033W$, where W is the weight of the vehicle being tested. For a conservative test the pulling force must not be less than $0.05W$ or $W/20$. The wheels must not rotate whilst the pulling force is applied. The load cell measurement is to be recorded as the parking brake force.

NOTE: Do not apply an excessive pulling force because it may physically skid the vehicle wheels and cause flat spots on the wheel treads.

Road-rail vehicles shall not normally be parked on rail for extended periods unless manned by an operator.

NOTE: Hydraulic motors used for driving rail wheels shall not be relied upon as a parking brake because of possible oil leakage through the motor which can allow the motor to free wheel.

5.3 Brake performance

The brakes shall stop the road-rail vehicle safely without skidding the wheels on dry track.

5.3.1 Deceleration requirement

The vehicle shall brake on dry level track within the following limits.

Vehicle Configuration	Measured Average Deceleration
All vehicles with steel wheels braking on rail.	0.9 m/s ² (0.09 g) minimum under all conditions
All vehicles with rubber tyres braking on rail (See Note 1)	1.1 m/s ² (0.11 g) minimum in tare condition
	1.0 m/s ² (0.10 g) minimum in loaded condition

Table 3 - Road-Rail Braking Requirements

NOTE 1: Includes vehicles with rear rubber tyres and front steel rail wheels braking on rail.

The brake performance test on road-rail vehicles shall be conducted with the operator applying the brake and not releasing until the vehicle is stationary. The vehicle shall be tested at normal operating speed, and at maximum allowable speed if safe to do so at the test site. The wheels must not skid during the test.

Trailers towed by road-rail vehicles shall be fitted with failsafe brakes. The trailer and towing vehicle shall be tested in accordance with that specified below.

Trailers shall be tested with the proposed hauling vehicle and the combination of hauling vehicle plus trailer shall comply with the deceleration requirements specified in Table 3 or, in the case of worksite only operation, in accordance with Clause 5.3.2 below.

A trailer that has been brake tested with a nominated towing vehicle is only authorised to operate with that vehicle. If an alternate towing vehicle is employed then it and the trailer combined, shall be re-tested for braking compliance.

5.3.2 Worksite only stopping distance requirement

Where road-rail vehicles are restricted to “worksite only” operation a brake functionality test may be carried out in lieu of measuring the deceleration. In this case the brakes on the vehicle shall be tested to demonstrate that they operate and bring the vehicle to a stand within 20 metres from 15 km/h. If the maximum speed of the vehicle is less than 15 km/h, then the vehicle shall still stop, from its maximum speed, within 20 metres.

6 Reflective Delineators

All road-rail vehicles shall be fitted with reflective zebra stripes. The stripes shall be fitted to the sides of the vehicle body, nominally at a height between 400 mm and 1500mm above ground level.

Vehicles with body lengths less than 2500 mm shall have continuous striping. Vehicles greater than 2500 mm may have spot striping at a maximum spacing of 1000mm between stripes. Placement shall highlight the extremities of the vehicle.

The width of the continuous reflective zebra stripe material shall nominally be 100 mm. Spot striping shall have a minimum area of 0.025 m² and a minimum length of 250mm.

The zebra stripes shall be at 45 degrees to the horizontal with a minimum colour bandwidth of 50 mm and manufactured from a reflective material compliant with AS1906.1 Class 1A. See Figure 17.

Stripes shall consist of any contrasting colours but **shall not** include the colours red or green.

In addition to the above requirements, outriggers, support legs, stabiliser legs, and similar equipment, which have the potential to protrude outside of the rolling stock outline, shall be highlighted with yellow and black reflective striping.

It should be noted that Rail Networks require red and yellow/orange reflective striping, applied to the rear of road-rail vehicles.

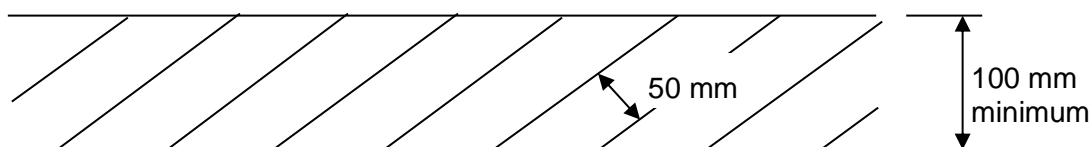

Figure 17 – Dimensions for Reflective Delineator Strips

7 Marking and lettering

7.1 Road registration and/or plant No

For ease of identification and listing, each road-rail vehicle shall be uniquely identified by a road vehicle registration plate and/or a plant No.

7.2 Rail industry certification

All road-rail vehicles must be certified annually for operation on rail. Each vehicle shall carry a certification label prominently displayed. Refer to CRN Standard CRN RS 016 covering the

Certification and Re-certification of Road-rail and Trailer/Trolley Infrastructure Maintenance Vehicles.

7.3 Compliance plates

All road/rail rail guidance systems manufactured or fitted after 1 March 2011 shall be fitted with a compliance plate.

Compliance plates similar to that shown in Figure 18 shall be permanently fitted to both front and rear rail guidance frames, in a low stress area.

The compliance plates shall be embossed or stamped with the following information:

- Rail Guidance Equipment Manufacturer
- Equipment Model Number (if applicable)
- Equipment Serial Number
- Date Equipment was manufactured
- Date installed on the vehicle

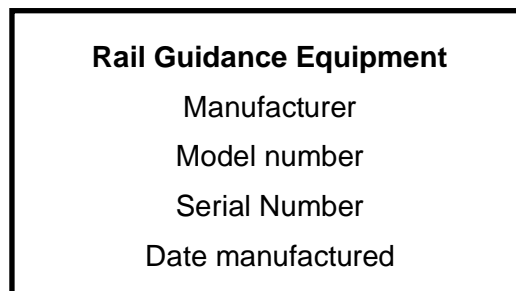

Figure 18 - Sample Road/rail equipment compliance plate

8 Road-rail vehicle ride performance

A ride performance test is required to ensure vehicle stability and compatibility with the track and to establish the optimum vehicle operating conditions.

A ride performance test is the basis for determining the maximum operating speed for vehicles. The maximum operating speed of road-rail vehicles is generally restricted to 30 km/h for vehicles of 5 tonne gross mass or more and 50 km/h for vehicles not exceeding 5 tonne gross mass. Where a vehicle meets all other requirements of this Standard and these speeds are not to be exceeded, a ride performance test may not be required, subject to the following clause.

The CRN Manager reserves the right to request and have a ride performance test carried out on any vehicle for the following reasons:

- Proposed modification to the suspension characteristics.
- Proposed change in wheel profile.
- Proposed change in vehicle operating conditions.
- Any proposed vehicle modification which may affect the vehicle ride performance.
- Significant change in the vehicle tare mass and/or redistribution of the vehicle mass.
- Where, in the CRN Manager's opinion, there is suspected poor ride performance.

Refer to CRN Standard CRN RS 010 for ride test requirements and methodology.

Parameter	Limit	Test Speed
Maximum lateral acceleration	+/-0.5g	110% design
Average lateral acceleration	+/-0.35g	110% design
Maximum vertical acceleration	+/-0.8g	110% design
Average vertical acceleration	+/-0.5g	110% design
Lateral Ride Index	3.5	110% design
Vertical Ride Index	3.5	110% design

Table 4 – Ride Test Performance Limits

The base ride performance criteria for all road/rail vehicles operating on the CRN shall be as shown in Table 4

The acceleration and ride index values given above are maximums for safe operation. For an acceptable ride quality, values much less than those are desirable.

9 Elevating work platforms (EWPs)

OHS Regulations require that high risk vehicles with lifting/elevating equipment, including boom-type EWPs and scissor lifts with a platform movement greater than 2.4 metres, be design registered in NSW before use. Once a design registration has been obtained, alterations that affect the safety of the vehicle must not be made until the alteration has been approved in accordance with local or federal laws. For EWPs such alterations include anything that affects the stability, centre of gravity, speed of travel, and/or safety features such as brakes, level indicators and motion-limiting switches.

Vehicles fitted with EWPs must comply with the requirements of AS 1418.10- Cranes, hoists and winches - Mobile elevating work platforms, and be design registered in accordance with local or federal law.

All elevating work platforms must be permanently mounted on the vehicle or attached through a robust fixed mounting system such as container twist locks.

NOTE: The use of an elevating work platform, of any type, chained to a flat bed truck or tray of any road-rail vehicle is **PROHIBITED** on the CRN.

9.1 Design registration

All elevating work platforms, with designs completed after 1 September 2001, must be design registered.

Elevating work platforms must have their design verified by a certified engineer regardless of the date of the design or manufacture.

9.2 EWP on-track stability

Road-rail vehicles fitted with an EWP shall be tested on rail, or simulated rail, for overturning stability in accordance with the requirements of AS 1418. The vehicle shall be tested under the most severe combination of design loading, design reach and track gradient and superelevation.

10 Towing & Recovery

Road-rail vehicles are permitted to tow road-rail or rail bound trailers on rail, provided the trailers are fitted with a failsafe braking system and the trailer brakes are proportionally controlled from the towing vehicle.

The GVM of a trailer shall not exceed the tare mass of the towing vehicle.

The towing fixtures shall be designed to withstand and transmit dynamic forces of at least equivalent to 5g without failure of any towing component.

Tail lighting control shall be transmitted to trailers.

Tow bars shall be appropriately identified with a compliance plate similar to that shown in Figure 18 and marked with the SWL for that that item of equipment.

Road-rail vehicles shall be fitted with recovery points enable towing from both front and rear by a second vehicle in case of break-down.

11 Protective structures

Road-rail vehicles which are used as earthmoving or lifting appliance vehicles, whilst operating on rail, with the capacity to reach trackside, shall have a protective structure for crew safety. Road-rail vehicles such as excavators, Pettibones, cranes, etc., having a mass of 700 kg or more, shall be fitted with a protective structure (ROPS and FOPS) that conforms with AS 2294.1, AS 2294.2 and AS 2294.3 - Earth-moving machinery - Protective structures - General.

For such vehicles manufactured, imported or originally purchased during or before 1981, if such a protective structure is not available, an alternative protective structure designed by a suitably qualified engineer having regard to the performance requirements of AS 2294.1, AS 2294.2 and AS 2294.3 - Earth-moving machinery - Protective structures – General, will be considered.

All road-rail tractors with a mass of between 560 kg and 15,000 kg shall be fitted with a protective structure (ROPS and FOPS) that conforms with AS 1636.1 - Tractors - Roll-over protective structures - Criteria and tests - Conventional tractors, AS 1636.2 - Tractors - Roll-over protective structures - Criteria and tests - Rear-mounted for narrow-track tractors and AS 1636.3 - Tractors - Roll-over protective structures - Criteria and tests - Mid-mounted for narrow-track tractors.

For tractors manufactured, imported or originally purchased during or before 1981, if such a structure is not available, an alternative protective structure designed by a suitably qualified engineer having regard to the performance requirements of the above standards, will be considered.

Vehicles such as excavators, rai-handlers, elevating work platforms and cranes that have equipment that can shift the vehicle centre of gravity shall be fitted with suitable motion limiters that prevent any wheel from unloading by more than 60% of static load.

12 Safety equipment

12.1 Speed indicating device

All road/rail vehicles capable of travelling in excess of 15 km/h in rail mode shall be fitted with an operative speed indicating device.

12.2 Data logger

Road-rail vehicles capable of operating above 30 km/h in rail mode shall be fitted with a functioning, reliable and accurate data recording device to record at least the following:-

- time
- speed

- brake application
- Data shall be recorded only when the vehicle is in rail operating mode.

12.3 Driver safety system

Road-rail vehicle shall comply with the requirements of CRN Standard CRN RS 013 - Driver Safety System Requirements for Rolling Stock.

The driver safety system must operate while the vehicle is in rail travel mode.

Vehicles with a potential for a kinematic energy of 600 Joules (kiloNewton metres) or less are exempt from driver safety systems. (Refer to CRN Standard CRN RS 013).

For road/rail vehicles operating as a locomotive refer to Section 14 herein.

12.4 Lighting

12.4.1 Head lights

Headlights on road-rail vehicles shall comply with the applicable Australian Design Rules for road vehicles.

Road-rail vehicles, able to travel at greater than 15 km/h or weighing in excess of 5 tonnes gross mass, shall have a headlight fitted at each leading end for operation in the direction of travel.

12.4.2 Tail, stop, marker and flashing lights

Road rail vehicles shall be fitted with tail and marker lights that comply with the applicable Australian Design Rules for road vehicles.

For on-track night operation road-rail vehicles that are required to readily operate in either direction shall be fitted with marker lights designed to display two (2) white lights on the leading end and two (2) red lights on the trailing end. The marker lights shall be automatically switchable such that they operate correctly for the direction of travel, even when the vehicle is making a reversing movement.

Reversing lights may be utilised as white marker lights during reversing operations.

Road-rail vehicles shall be fitted with stop lights that comply with the applicable Australian Design Rules for road vehicles.

Irrespective of the speed of operation, the vehicle shall be fitted with an **orange flashing light**. The flashing light must be activated at all times when the vehicle is on rail and the ignition is switched on. Each beacon shall have a luminous intensity of at least 18,000 candela with a flash rate between 40 and 180 flashes per minute.

The flashing light must be visible to a person standing 4 metres, in any direction, from the vehicle. If the flashing light is not visible from any side/end, then additional flashing lights will be required.

12.5 Audible Warning Device

All road/rail vehicles shall be fitted with a **reverse alarm**, which is clearly audible and automatically activated when reverse gear is selected.

Road-rail excavators and plant with restricted operator vision in both forward and reverse directions must be fitted with a travel alarm, which operates in both directions.

Alternatively, two alarms may be fitted. The alarm must be activated automatically for each direction of travel.

The alarm's output must vary in response to changes in the surrounding noise level, (eg "Smart Alarm"). The alarm's noise level range shall be 87 to 112 dBA measured at a distance of 1 metre from the vehicle. Self adjusting type alarms must be mounted with an unobstructed 'vision' to the

rear of the vehicle. Fixed output reverse alarms originally fitted by the equipment manufacturer are acceptable.

The vehicle shall also have a horn equivalent to that of an automotive horn.

12.6 Height, slew and reach restrictors

Road-rail vehicles such as excavators, Pettibones, EWPs and cranes that have lifting equipment or jib attachments capable of elevating above the vehicle or slewing towards trackside shall be fitted with restrictors to prevent equipment over-travel.

Height restrictors are required where there is risk of equipment fouling or bringing personnel too close to overhead electrical wiring or structures.

Slew and or reach restrictors are required to prevent vehicles becoming unstable when working their lifting equipment beyond safe limits.

12.7 Electrical

A lockable battery isolator shall be fitted. Low beam headlights and tail lights shall be automatically turned on when hi-rail equipment is not fully retracted.

12.8 Access

The top surface of the bottom rung or step of cab access should be no more than 200mm above top of rail when operating on-track.

12.9 Maintenance

Vehicle maintenance shall be based on the vehicle manufacturer's recommendations, but as a minimum, should include the applicable requirements of RISSB Guideline: Operating Road/Rail vehicles.

13 Testing

The elements of a road-rail vehicle acceptance inspection and testing regime are covered in CRN Standard CRN RS 010.

Refer to CRN Standard CRN RS 016 for Road-rail Infrastructure Maintenance Vehicle Certification and Re-certification.

14 Road-rail vehicles operating as a locomotive

14.1 General

A limited number of road-rail vehicles have the capacity to operate as a locomotive and haul freight vehicles. The braking system in this case must be compatible between the road-rail vehicle and the hauled vehicles.

Some road-rail vehicles may be used to tow a trailer. Refer to CRN Standard CRN RS 007 - Minimum Operating Requirements for Infrastructure Maintenance Trolleys and Trailers.

This section covers the requirements for such vehicles operating as a locomotive and hauling freight vehicles within a protected worksite.

14.2 Vehicle identification

Road-rail vehicles authorised to operate as a locomotive must have the maximum allowable trailing train mass that can be hauled marked on the sides of the vehicle and in the vehicle drivers cab.

Road-rail vehicles authorised to operate as a locomotive shall be clearly identified in the CRN Train Operating Conditions (TOC) Manual, Section 11 - Infrastructure Maintenance Vehicle Data.

14.3 Authorisation of the vehicle

Road-rail vehicles must be accepted for operation on the CRN, as specified in Section 1.7 herein.

For an infrastructure vehicle to be authorised to operate as a locomotive, the vehicle must comply with the following requirements for locomotives as detailed in CRN Standard CRN RS 001.

14.3.1 Brakes and pneumatic equipment

The automatic air braking system on the road-rail vehicle must be compatible with the braking system of vehicles to be hauled. The brake pipe must be regulated to 500 kPa and the driver's automatic brake valve shall be capable of charging the brake pipe when in release, reducing the brake pipe pressure when applying the brakes and fully exhausting the brake pipe when in emergency. The compressor and airbrake supply reservoir capacity must be sufficient to ensure that all the brakes must release within 15 seconds after the brake handle is placed in the release position following a full service application.

If the vehicle is hauling vehicles that may use main reservoir air for auxiliary equipment, such as ballast wagons with air operated discharge doors, the reservoir sizes must take into account the use of the main reservoir air. The length of train may need to be reduced to meet main reservoir limitations.

The operator's cab shall be fitted with a main reservoir and a brake pipe pressure gauge. All cut-out or isolation cocks must be clearly identified and handles painted white.

14.3.2 Couplers

The couplers and draftgear shall be suitable for the maximum loads hauled by the infrastructure vehicle. The coupler height shall be within the limits 840 to 900 mm above rail.

14.3.3 Traction performance

The mass of the road-rail vehicle on rail shall be sufficient to provide the required adhesive tractive effort to control wagons during both acceleration and braking.

Testing shall be conducted or evidence provided that the vehicle is capable of hauling the specified maximum loads on various grades.

14.3.4 Braking performance

Tests shall be conducted on the road-rail vehicle with the maximum approved number of loaded vehicles to ensure the satisfactory operation of the braking system.

Stopping distance tests shall be conducted to ensure the train consist stops within the requirements of CRN Standard CRN RS 001, Section 14.4.2.

14.3.5 Safety equipment

Road-rail vehicles operating as locomotives must be fitted with the following safety equipment as specified in CRN Standard CRN RS 001.

- Driver's safety system
- Speed indicating device
- Data logger/recorder
- Driver's emergency cock
- Flowmeter
- Emergency equipment
- Communications equipment
- Lights

- Horns.

The timings for the vigilance control system must be in accordance with reduced timings for driver only operation as specified in CRN Standard CRN RS 013.

14.3.6 Operation of infrastructure vehicle as a locomotive

Before a road-rail vehicle is to be used to haul a train, the vehicle and train must be marshalled together and all air brake coupling hoses coupled and coupling cocks between vehicles opened.

The train must be inspected in accordance with the CRN Train Operating Conditions (TOC) Manual, General Instruction Pages, Section 6 Train Inspection.

14.3.7 Driver safety system

Road-rail vehicles used to haul a train must be fitted with a driver safety system in accordance with CRN Standard CRN RS 013 - Driver Safety System Requirements for Rolling stock, and the following requirements.

Where the vehicle is crewed by a driver and a second Qualified Worker, the vehicle must be fitted with a vigilance control system.

Where the vehicle is crewed by a single driver, the vehicle shall be fitted with a vigilance control system AND an Operator Enable system. Refer to CRN Standard CRN RS 013.

Appendix 1 CRN Rolling Stock Glossary

This appendix defines words that are used in the CRN Rolling Stock Standards

Agreed	Agreed between the Owner/Operator and the CRN Manager.
Approved	Approved by the CRN Manager.
Authorised person	Person authorised to travel in the cab of an infrastructure maintenance vehicle/train and stop the vehicle/train in the event of an emergency.
Cant deficiency	The difference in superelevation between: that required to balance the actual vehicle centrifugal force due to curve negotiation such that there is equal wheel loading on the high and low rail, (equilibrium or balancing speed), and the actual superelevation existing in the curve. Cant deficiency is a function of superelevation, curve radius and vehicle speed.
Continuous tractive effort	The tangential force that can be applied at the wheel/rail interface by a self powered vehicle for an indefinite period without causing wheel spin or overheating of the traction equipment.
Curved wheel web	Wheel web or plate which is domed such that its cross section is curved.
Design speed	The maximum speed at which a vehicle is expected to operate on the CRN.
Flat top trolley or trailer	A small non-powered infrastructure maintenance vehicle which is used for conveying tools and equipment along the track and which can be easily removed from the track.
Freight Train	A train predominantly consisting of freight vehicles.
FOPS	Falling Object Protective Structures
Full supplies, Fully provisioned	Locomotive with all equipment and full of fuel, oil, water, coolant and sand.
Handbrake	A mechanical device provided on a train/vehicle in order to secure the train or an individual vehicle so as to prevent it from moving. Note: Where the term “handbrake” is used, it will also mean “parking brake”.
Heritage vehicle	Locomotive, passenger vehicle, freight vehicle or trolley that has historical significance and/or is not used in regular revenue service but used in special interest operations, such as steam tours.
Infrastructure maintenance vehicle	A rail bound self propelled vehicle which is used to carry out inspection and/or maintenance on railway infrastructure. Some of these vehicles may be removed from the railway track by the use of special take-offs or portable turnouts.
Light locomotive	One or more locomotives coupled together without hauled vehicles attached.
Locomotive	A self propelled vehicle, powered by any form of energy, which does not convey passengers or freight but which is used to move one or more other vehicles thus forming a train.
Multiple unit train	A distributed power train made up of similar electric or diesel powered vehicles and non-powered vehicles operating as a unit.
Net brake ratio	The ratio of the sum of the actual measured brake block forces divided by the total vehicle weight.



On-track infrastructure maintenance vehicle	Any infrastructure maintenance vehicle which operates exclusively on railway track.
Overhead wiring vehicle	An infrastructure maintenance vehicle with an elevating platform or equipped for maintenance of the overhead traction wiring system.
Power car	A self propelled vehicle, which may or may not convey passengers and/or freight, and operates in conjunction with similar vehicles in a multiple unit consist.
Quadricycle	A small self propelled rail-bound track vehicle which can be easily removed from the track.
Qualified worker	A worker certified as competent to carry out the relevant task.
Rail-bound infrastructure maintenance vehicle	An on-track infrastructure maintenance vehicle that cannot be removed from track without the use of a heavy crane. These vehicles are transferred around the network by rail.
Road/rail vehicle	Any type of track vehicle which can travel on either road or rail and can readily transfer from one mode of operation to the other.
Rolling Stock Exemption Certificate	A Certificate issued to a vehicle owner/operator covering vehicle non-conformances which are technically acceptable. These certificates remain in place for the life of the vehicle.
Rolling Stock Standards Waiver	A Waiver issued for a vehicle covering non-conformances that are deemed acceptable for a limited time period, until corrected.
ROPS	Roll-over Protective Structures
Starting tractive effort	The tangential force applied at the wheel/rail interface that can be applied by self powered vehicle, to move itself and its trailing load from a stationary state without causing excessive wheel slip.
Straight wheel web	Wheel web consisting of a flat plate with no curvature such that its cross section is straight. Used primarily with wheel cheek mounted disc brakes
S-plate wheel	Wheel with a web such that its cross section forms an S shape, designed to provide low wheel rim stresses
Substantially modified vehicle	Vehicle modified to accommodate its use for a different purpose. Vehicle undergoing major refurbishment with updated equipment which can alter the braking, traction or suspension system performance. Vehicle being moved with equipment removed resulting in a reduction of vehicle mass that could alter the vehicle performance. Vehicle modified such that it may be incompatible with the infrastructure.
TOC Waiver	An authority issued for the movement of a vehicle for which there are no published operating conditions, or for which the operating conditions are different from those published in the CRN Train operating Conditions Manual.
Track maintenance vehicle	Infrastructure maintenance vehicle used for the maintenance, construction or inspection of track.
Train	One or more rail vehicles operating singularly or coupled together, hauled or self powered and capable of operating track signal circuits